

*SLASH oildynamic pivot system*

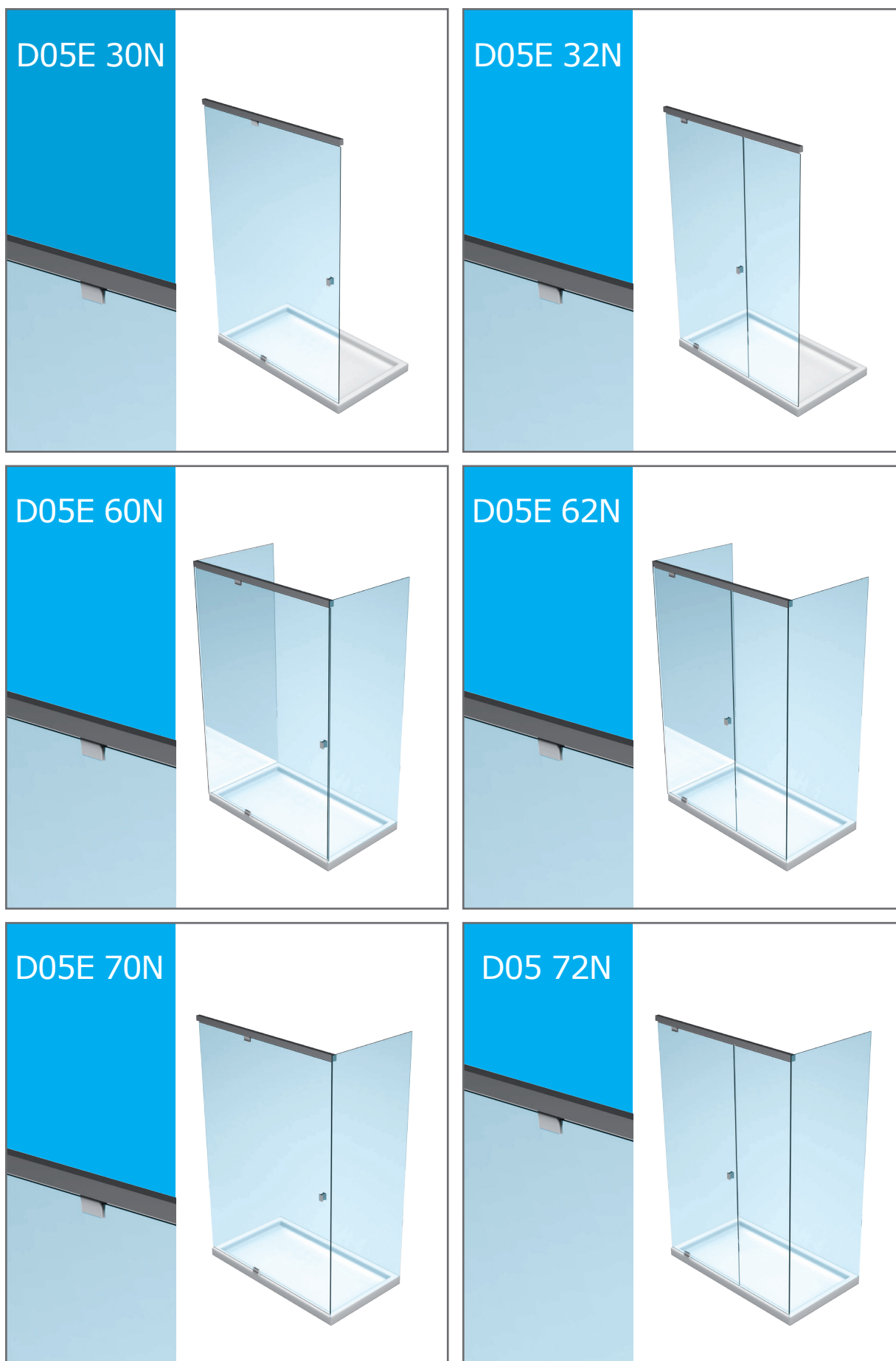

## D05E 30N

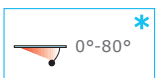
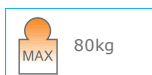

Da specificare all'ordine - Especificar en el pedido - Specify at time of order - Bitte mit der Bestellung genau angeben



D05E 30N/08

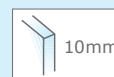

D05E 30N/10

### SLASH oildynamic pivot system

- Kit Slash per box doccia in nicchia a tutta larghezza. Stop +90°.
- Kit Slash para box ducha de nicho a anchura total. Stop a +90°.
- Slash niche set wall-wall. One door. Stop at 90°.
- Set Slash für Duschnische Wand-Wand. Eine Tür. +90° Feststellung.

\*

È necessaria una battuta in chiusura in quanto la cerniera ha una precarica - Necesita de un cierre con tope, puesto que la bisagra tiene una precarga - The hinge is preloaded which makes an end stop necessary - Ein Anschlag ist notwendig, da der Beschlag eine Vorspannung besitzt.

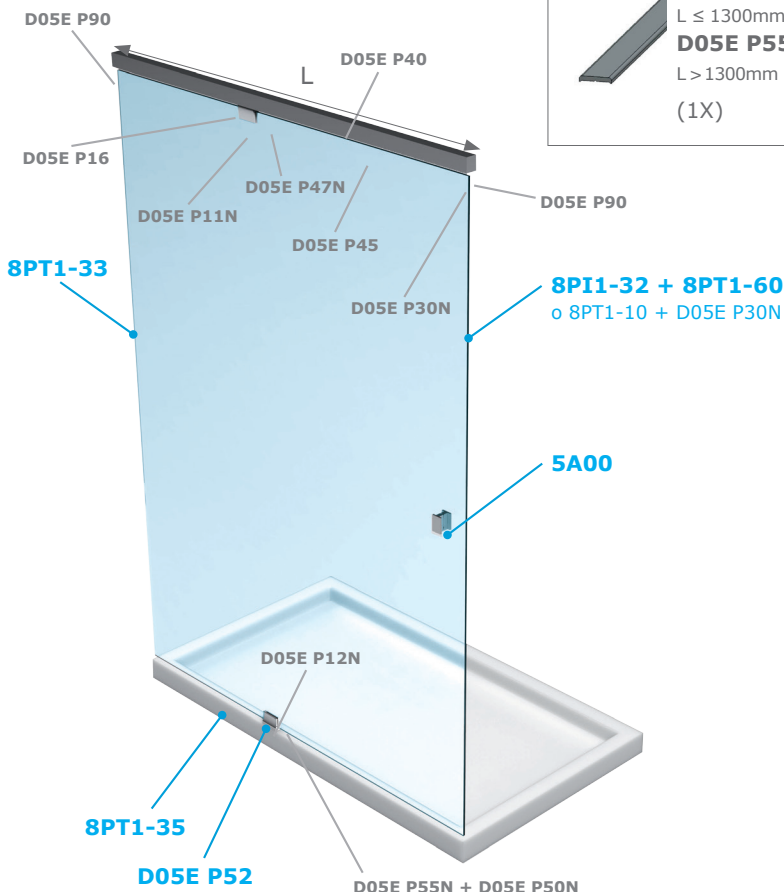

### Compreso / Included



D05E P16 (1X)

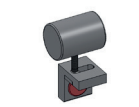

D05E P30N (1X)



D05E P11N/08 (1X)  
(vetro/vidrio/glass/Glas 8mm)

D05E P11N/10 (1X)  
(vetro/vidrio/glass/Glas 10mm)



D05E P12N/08 (1X)  
(vetro/vidrio/glass/Glas 8mm)

D05E P12N/10 (1X)  
(vetro/vidrio/glass/Glas 10mm)



D05E P47N (1X)



D05E P90 (2X)

### Non compreso / Not included

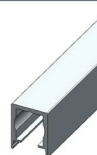

D05E P40/13 (1,25 mt)

L ≤ 1300mm (630mm MIN)

D05E P40/18 (1,75 mt)

L > 1300mm (1800mm MAX)

(1X)

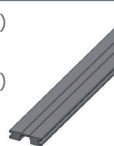

D05E P45/09

(0,9 mt)

(1X) L ≤ 900mm

(2X) L > 900mm



D05E P55N/13 (1,3 mt)

L ≤ 1300mm (630mm MIN)

D05E P55N/18 (1,8 mt)

L > 1300mm (1800mm MAX)

(1X)



D05E P50N

(1X)

### OPTIONAL

Coperture inox per - Cubiertas de acero inoxidable para - Stainless steel covers for - Abdeckungen aus Edelstahl für

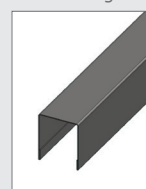

D05E P40

C D05E P40/13

C D05E P40/18

(1X)



D05E P90

C D05E P90

(1X)

Profilo deviatore antischiacciamento - Perfil desviador anti aplastamiento - Seal against finger crush - Fingerklemmschutzprofil

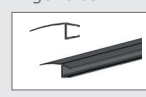

8PT1-33

(1X)

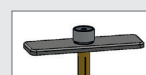

D05E P52

(1X)

## D05E 30N SLASH system

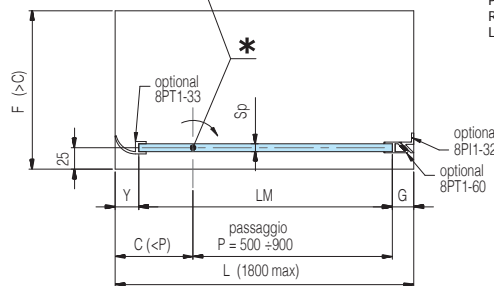
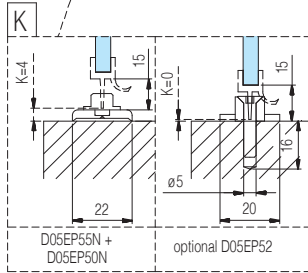
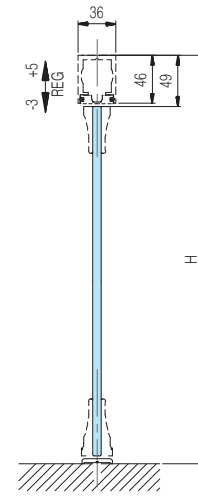
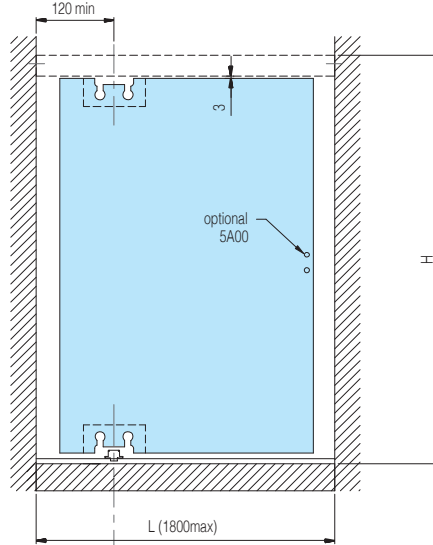
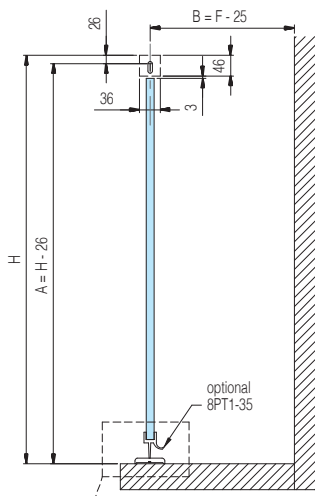

\*  
CENTRO DI ROTAZIONE  
PUNTO DE ROTACION  
ROTATION POINT  
LAGE DER DREHACHSE

Sp	Y	G
8mm	18mm	17mm
10mm	18mm	20mm

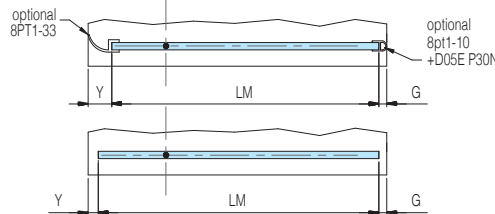
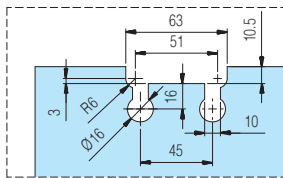

Sp	Y	G
8mm	18mm	6mm
10mm	18mm	8mm

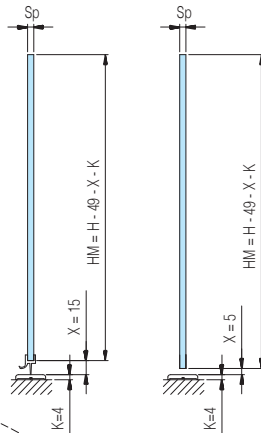
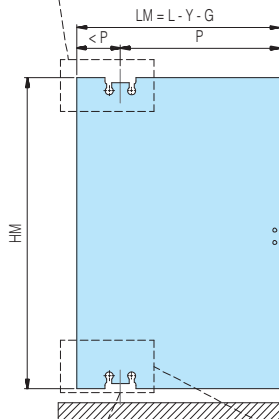

Sp	Y	G
8mm	3mm	3mm
10mm	3mm	3mm

\*  
Definire il passaggio P voluto. Valutare il centro di rotazione e definire la larghezza LM totale.

Definir el pasaje P deseado. El centro de la vuelta de evaluar y definir el ancho total LM.

Define the desired passage P. Consider the rotation point and define the total width LM.

Den gewünschte Durchgang P definieren. Auf den Drehpunkt achten und die Gesamtbreite LM definieren.

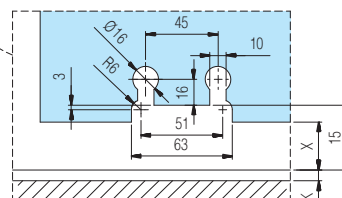
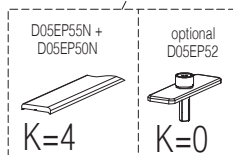

## D05E 32N

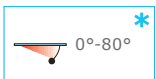

### SLASH oildynamic pivot system

- Kit Slash per box doccia in nicchia con vetro fisso frontale. Stop a +90°.
- Kit Slash para box ducha de nicho con vidrio delantero fijo. Stop a +90°.
- Slash niche set wall-wall. 1 door and 1 fixed panel. Stop at 90°.
- Set Slash für Duschnische Wand-Wand. Eine Tür und ein Seitenteil. +90° Feststellung.

\*

È necessaria una battuta in chiusura in quanto la cerniera ha una precarica - Necesita de un cierre con tope, puesto que la bisagra tiene una precarga - The hinge is preloaded which makes an end stop necessary - Ein Anschlag ist notwendig, da der Beschlag eine Vorspannung besitzt.

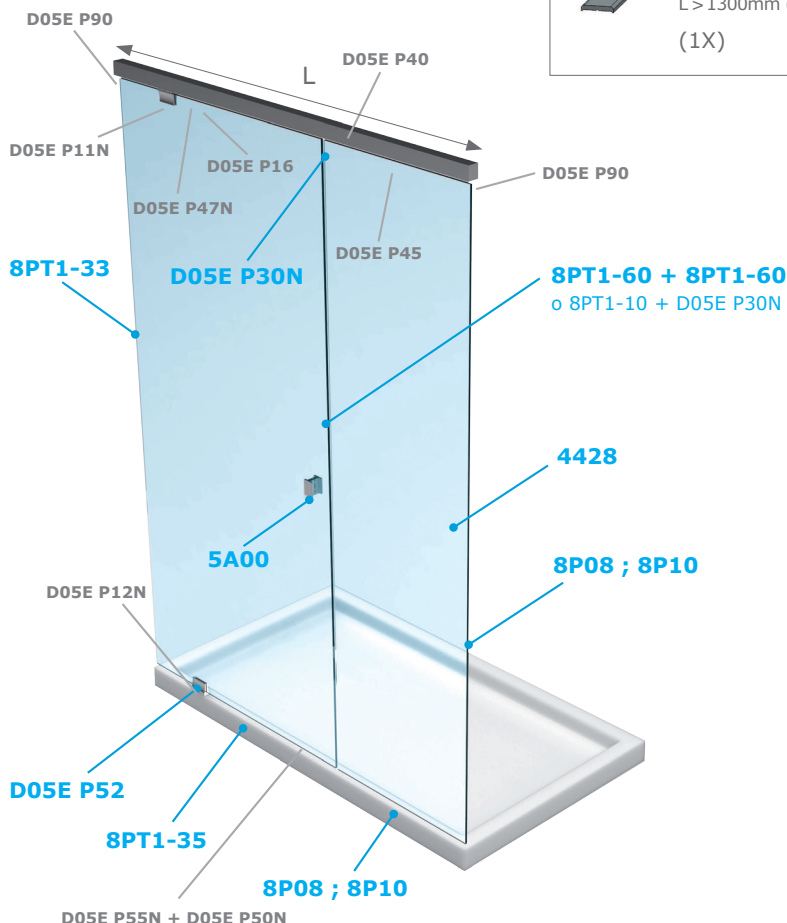

Da specificare all'ordine - Especificar en el pedido - Specify at time of order - Bitte mit der Bestellung genau angeben



D05E 32N/08



D05E 32N/10

### Compresso / Includo

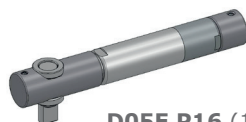

D05E P11N/10 (1X)  
(vetro/vidrio/glass/Glas 10mm)



D05E P12N/10 (1X)  
(vetro/vidrio/glass/Glas 10mm)



### Non compreso / Not included

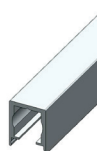

D05E P40/18 (1,75 mt)  
L > 1300mm (1800mm MAX)

(1X)

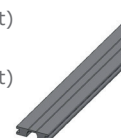

(1X) L ≤ 900mm  
(2X) L > 900mm



D05E P55N/18 (1,8 mt)  
L > 1300mm (1800mm MAX)

(1X)



(1X)

### OPTIONAL

Coperture inox per - Cubiertas de acero inoxidable para - Stainless steel covers for - Abdeckungen aus Edelstahl für

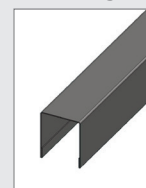

C D05E P40/13  
C D05E P40/18 (1X)

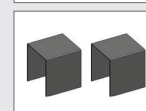

C D05E P90 (1X)

Profilo deviatore antischiacciamento - Perfil desviador anti aplastamiento - Seal against finger crush - Fingerklemmschutzprofil

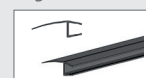

Fermo - Tope - Stop - Endanschlag

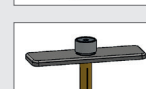
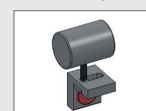

## D05E 32N SLASH system

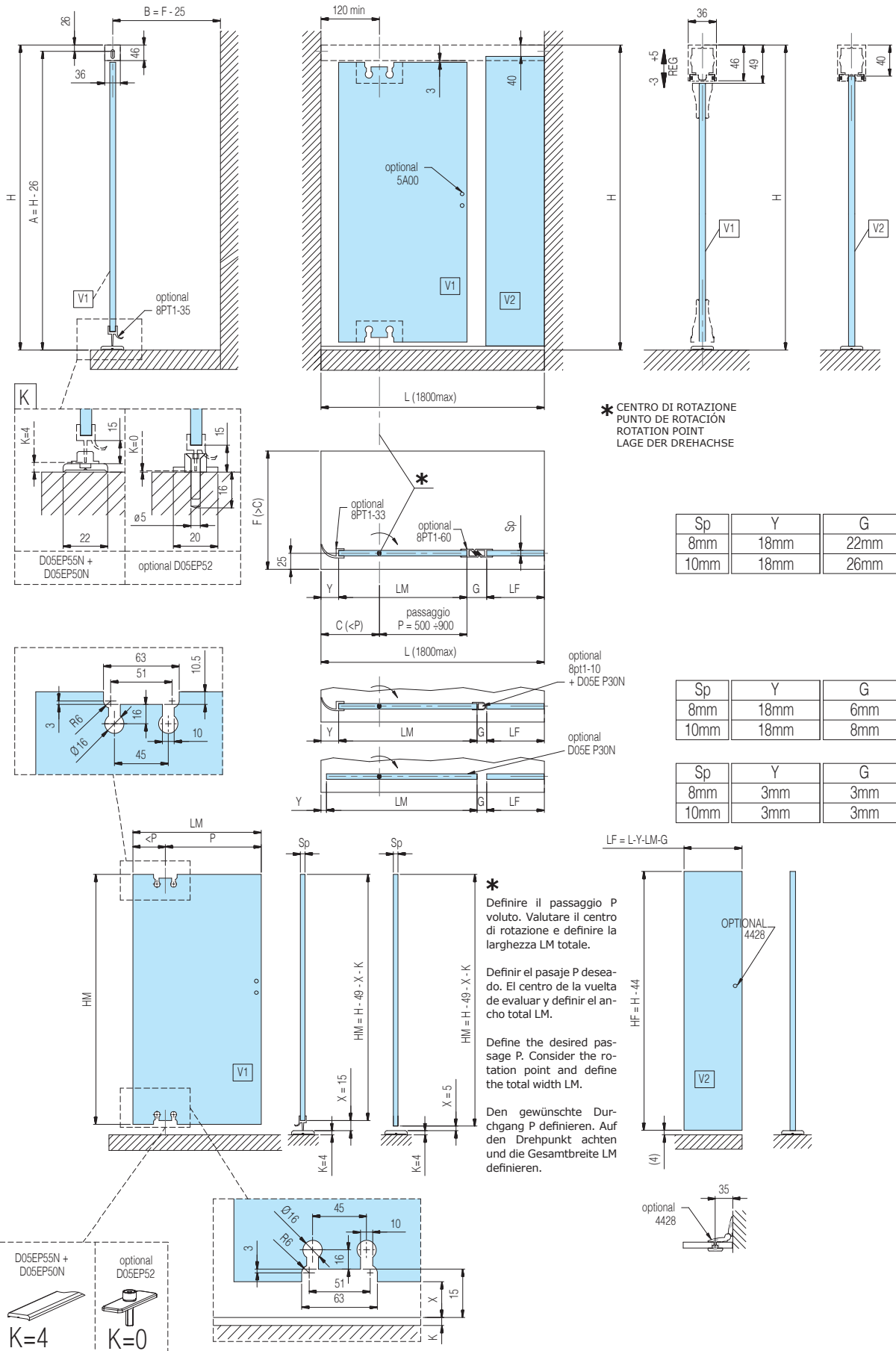

## D05E 60N

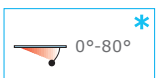
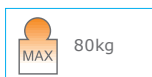

### SLASH oildynamic pivot system

- Kit Slash per box doccia con 2 spalle in vetro. Stop a +90°.
- Kit Slash de ducha con 2 paneles traseros en cristal. Stop a +90°.
- Slash set for shower tray glass-glass . One door. Stop at +90°.
- Set Slash für Glas-Glas Dusche. Eine Tür. Feststellung +90°.

\*

È necessaria una battuta in chiusura in quanto la cerniera ha una precarica - Necesita de un cierre con tope, puesto que la bisagra tiene una precarga - The hinge is preloaded which makes an end stop necessary - Ein Anschlag ist notwendig, da der Beschlag eine Vorspannung besitzt.

Da specificare all'ordine - Especificar en el pedido - Specify at time of order - Bitte mit der Bestellung genau angeben



D05E 60N/08



D05E 60N/10

### Compresso / Included



D05E P16 (1X)

D05E P11N/08 (1X)  
(vetro/vidrio/glass/Glas 8mm)

D05E P11N/10 (1X)  
(vetro/vidrio/glass/Glas 10mm)



D05E P12N/08 (1X)  
(vetro/vidrio/glass/Glas 8mm)

D05E P12N/10 (1X)  
(vetro/vidrio/glass/Glas 10mm)

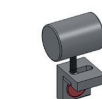

D05E P30N  
(1X)



D05E P47N  
(1X)



D05E P80  
(2X)



D05E P90  
(2X)

### Non compreso / Not included



D05E P40/13 (1,25 mt)  
L ≤ 1300mm (630mm MIN)

D05E P40/18 (1,75 mt)  
L > 1300mm (1800mm MAX)  
(1X)

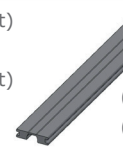

D05E P45/09  
(0,9 mt)

(1X) L ≤ 900mm  
(2X) L > 900mm



D05E P55N/13 (1,3 mt)  
L ≤ 1300mm (630mm MIN)

D05E P55N/18 (1,8 mt)  
L > 1300mm (1800mm MAX)  
(1X)



D05E P50N  
(1X)

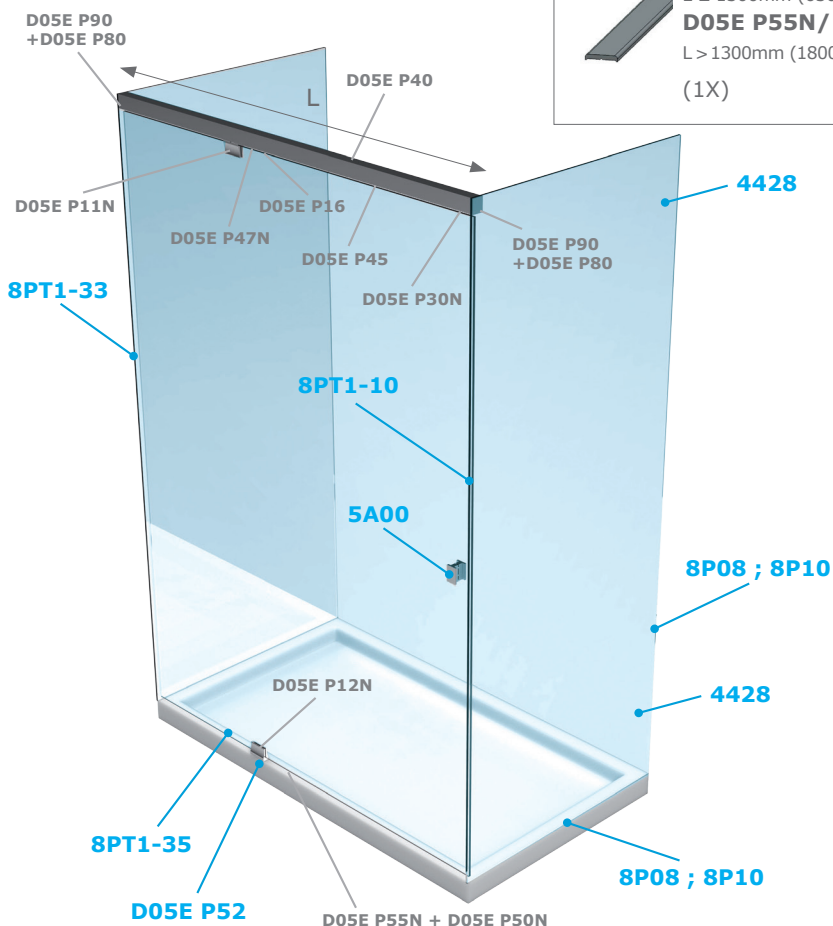

### OPTIONAL

Coperture inox per - Cubiertas de acero inoxidable para - Stainless steel covers for - Abdeckungen aus Edelstahl für

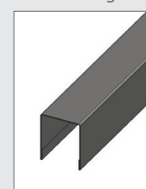

D05E P40

C D05E P40/13  
C D05E P40/18  
(1X)



D05E P90

C D05E P90  
(1X)

Profilo deviatore antischiacciamento - Perfil desviador anti aplastamiento - Seal against finger crush - Fingerklemmschutzprofil

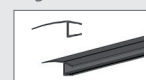

8PT1-33  
(1X)

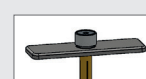

D05E P52  
(1X)



## D05E 60N SLASH system

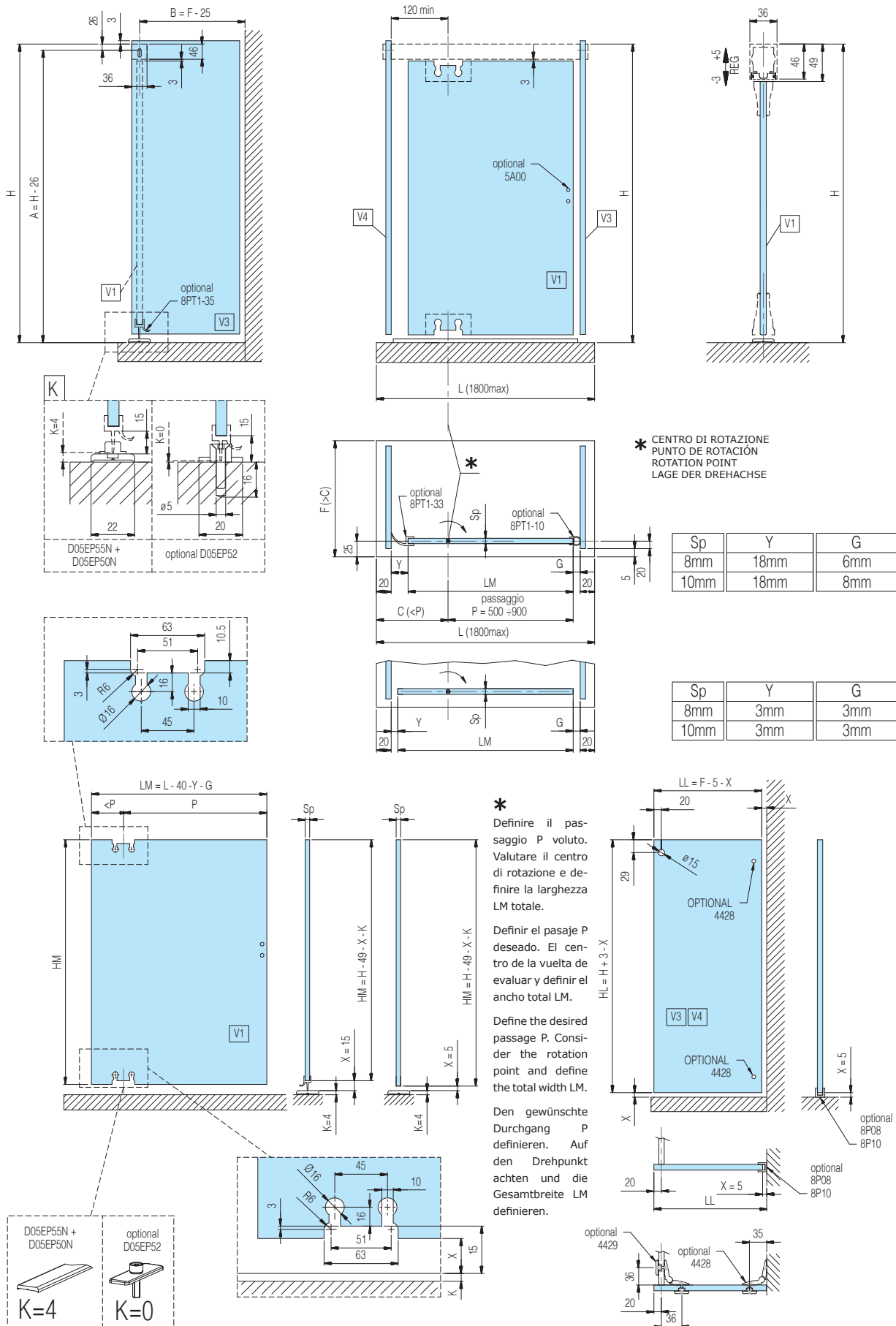

## D05E 62N

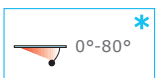
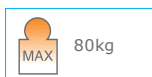
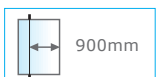

### SLASH oildynamic pivot system

- Kit Slash per box doccia con 2 spalle in vetro. Con vetro fisso frontale. Stop a +90°.
- Kit Slash de ducha con 2 paneles traseros en cristal. Frente de cristal fijo. Stop a + 90°.
- Slash set for shower tray glass-glass. 1 door and fixed glass. Stop at +90°.
- Set Slash für Glas-Glas Dusche. Eine Tür und ein Seitenteil. +90° Feststellung.

\*

È necessaria una battuta in chiusura in quanto la cerniera ha una precarica - Necesita de un cierre con tope, puesto que la bisagra tiene una precarga - The hinge is preloaded which makes an end stop necessary - Ein Anschlag ist notwendig, da der Beschlag eine Vorspannung besitzt.

Da specificare all'ordine - Especificar en el pedido - Specify at time of order - Bitte mit der Bestellung genau angeben



D05E 62N/08



D05E 62N/10

### Compreso / Included



D05E P16 (1X)

D05E P11N/08 (1X)

(vetro/vidrio/glass/Glas 8mm)

D05E P11N/10 (1X)

(vetro/vidrio/glass/Glas 10mm)



D05E P12N/08 (1X)

(vetro/vidrio/glass/Glas 8mm)

D05E P12N/10 (1X)

(vetro/vidrio/glass/Glas 10mm)



D05E P47N

(1X)



D05E P80

(2X)



D05E P90

(2X)

### Non compreso / Not included

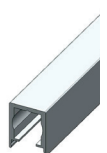

D05E P40/13 (1,25 mt)

L ≤ 1300mm (630mm MIN)

D05E P40/18 (1,75 mt)

L > 1300mm (1800mm MAX)

(1X)



D05E P55N/13 (1,3 mt)

L ≤ 1300mm (630mm MIN)

D05E P55N/18 (1,8 mt)

L > 1300mm (1800mm MAX)

(1X)

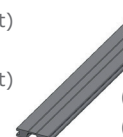

D05E P45/09

(0,9 mt)

(1X) L ≤ 900mm

(2X) L > 900mm



D05E P50N

(1X)

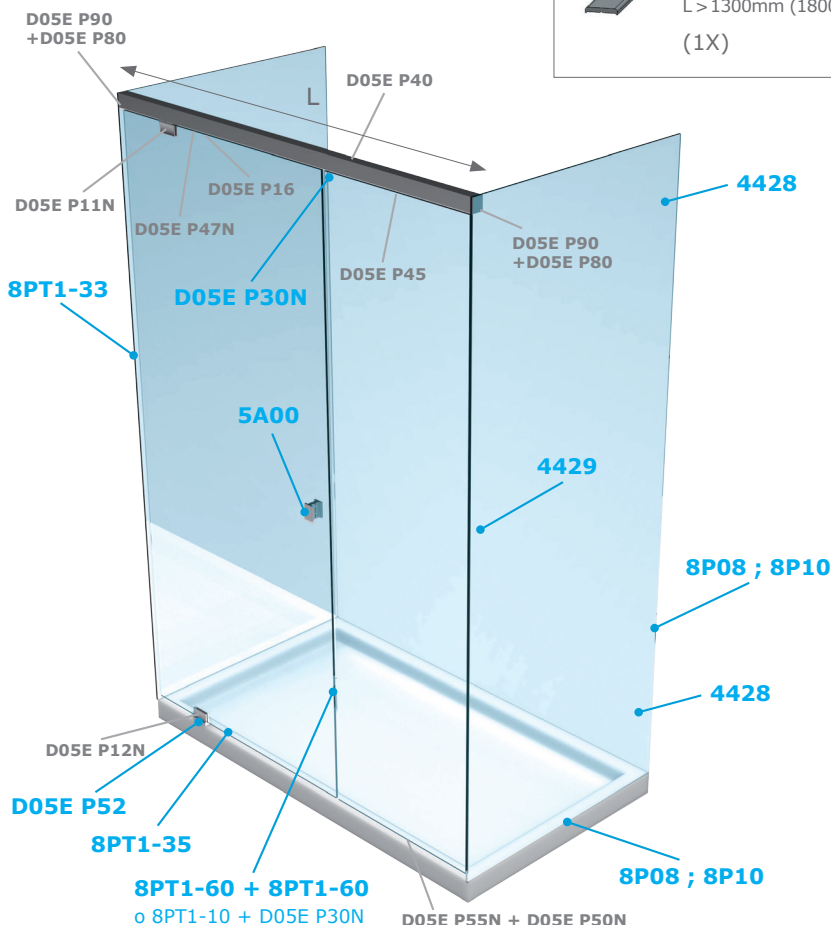

### OPTIONAL

Coperture inox per - Cubiertas de acero inoxidable para - Stainless steel covers for - Abdeckungen aus Edelstahl für

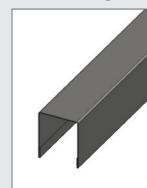

D05E P40

C D05E P40/13

C D05E P40/18

(1X)



D05E P90

C D05E P90

(1X)

Profilo deviatore antisciacchiamento - Perfil desviador anti aplastamiento - Seal against finger crush - Fingerklemmschutzprofil



8PT1-33

(1X)

Fermo - Tope - Stop - Endanschlag



D05E P30N

(1X)

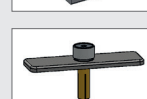

D05E P52

(1X)



## D05E 62N SLASH system

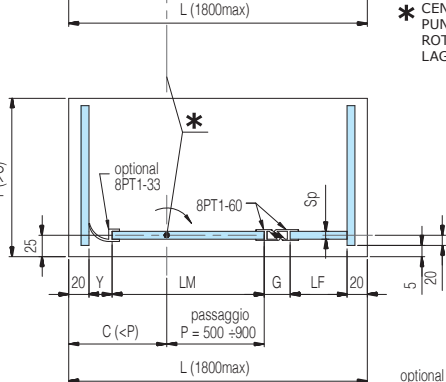
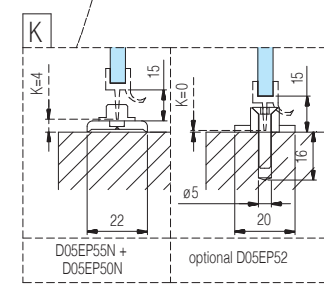
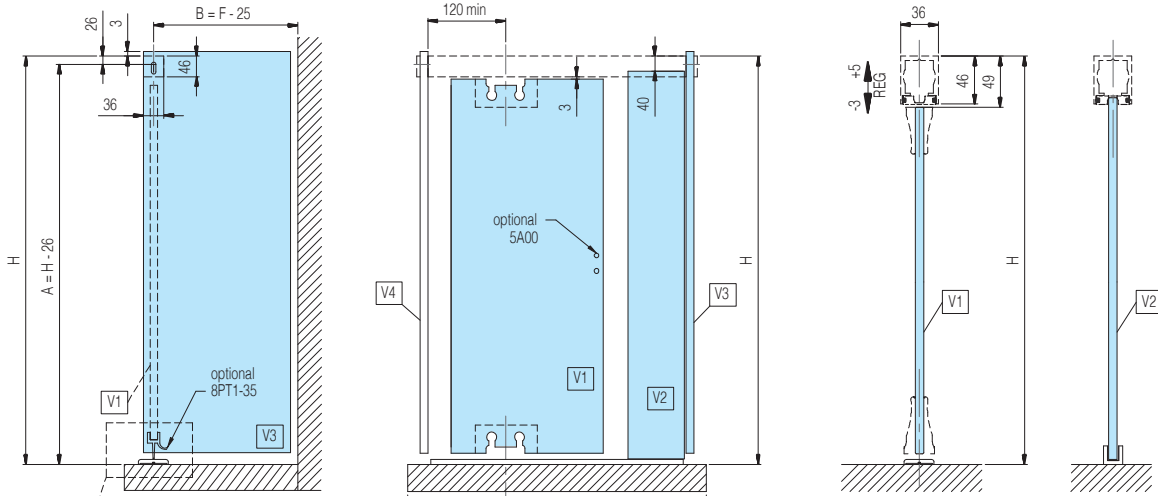

\* CENTRO DI ROTAZIONE  
PUNTO DE ROTACION  
ROTATION POINT  
LAGE DER DREHACHSE

\* Definire il passaggio P voluto. Valutare il centro di rotazione e definire la larghezza LM totale.  
Definir el pasaje P deseado. El centro de la vuelta de evaluar y definir el ancho total LM.  
Define the desired passage P. Consider the rotation point and define the total width LM.  
Den gewünschte Durchgang P definieren. Auf den Drehpunkt achten und die Gesamtbreite LM definieren.

Sp	Y	G
8mm	18mm	22mm
10mm	18mm	26mm

Sp	Y	G
8mm	18mm	6mm
10mm	18mm	8mm

Sp	Y	G
8mm	3mm	3mm
10mm	3mm	3mm

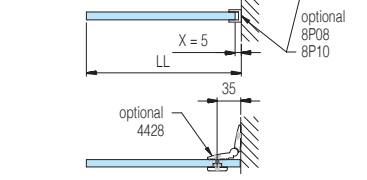
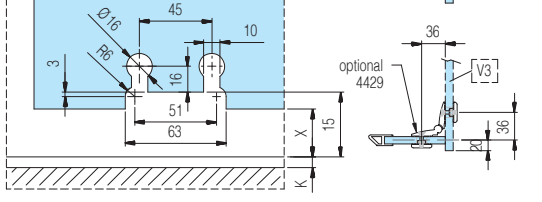
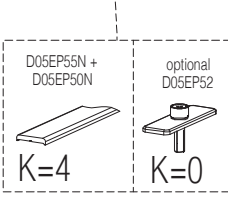
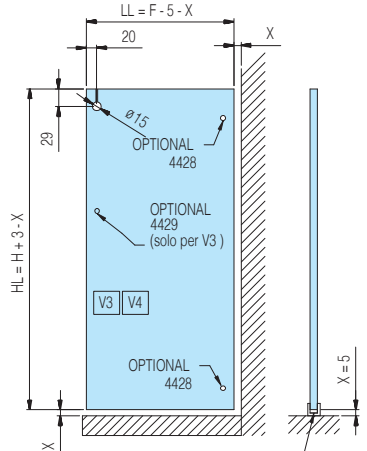
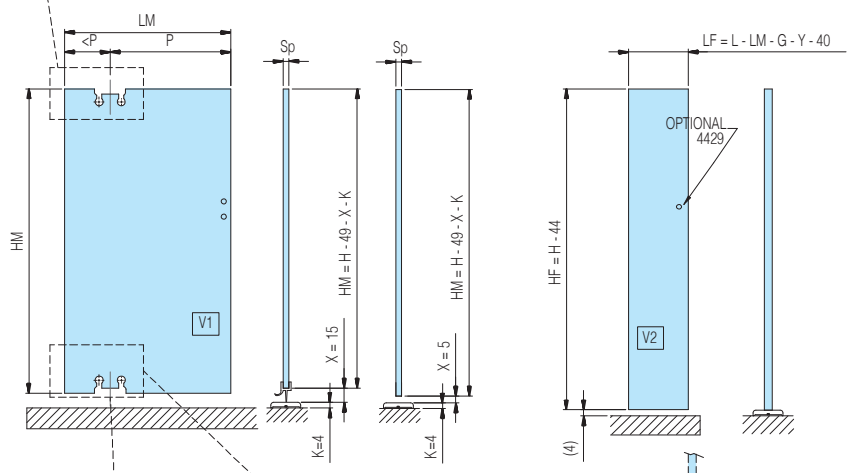
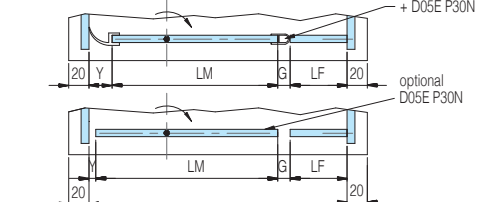
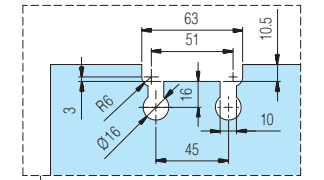

## D05E 70N

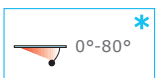

### SLASH oildynamic pivot system

- Kit Slash per box doccia con 1 spalla in vetro. Stop a +90°.
- Kit Slash para box ducha: 1 lado en vidrio. Stop a +90°.
- Set Slash for shower tray wall-glass. One door. Stop at +90°.
- Set Slash für Wand-Glas Dusche. Eine Tür. +90° Feststellung.

\*

È necessaria una battuta in chiusura in quanto la cerniera ha una precarica - Necesita de un cierre con tope, puesto que la bisagra tiene una precarga - The hinge is preloaded which makes an end stop necessary - Ein Anschlag ist notwendig, da der Beschlag eine Vorspannung besitzt.

Da specificare all'ordine - Especificar en el pedido - Specify at time of order - Bitte mit der Bestellung genau angeben



D05E 70N/08



D05E 70N/10

### Compresso / Included



D05E P16 (1X)

D05E P11N/08 (1X)  
(vetro/vidrio/glass/Glas 8mm)

D05E P11N/10 (1X)  
(vetro/vidrio/glass/Glas 10mm)



D05E P12N/08 (1X)  
(vetro/vidrio/glass/Glas 8mm)

D05E P12N/10 (1X)  
(vetro/vidrio/glass/Glas 10mm)



D05E P30N  
(1X)



D05E P47N  
(1X)



D05E P80  
(1X)



D05E P90  
(2X)

### Non compreso / Not included



D05E P40/13 (1,25 mt)  
L ≤ 1300mm (630mm MIN)

D05E P40/18 (1,75 mt)  
L > 1300mm (1800mm MAX)  
(1X)

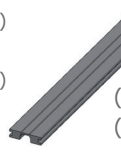

D05E P45/09  
(0,9 mt)

(1X) L ≤ 900mm  
(2X) L > 900mm



D05E P55N/13 (1,3 mt)  
L ≤ 1300mm (630mm MIN)

D05E P55N/18 (1,8 mt)  
L > 1300mm (1800mm MAX)  
(1X)



D05E P50N  
(1X)

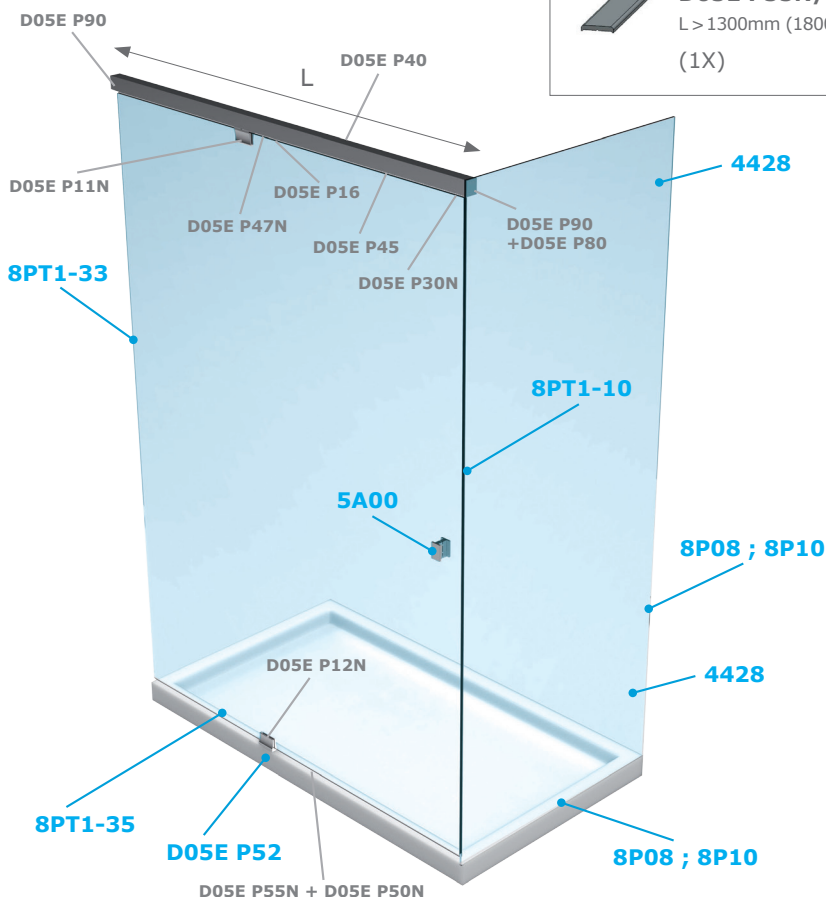

### OPTIONAL

Coperture inox per - Cubiertas de acero inoxidable para - Stainless steel covers for - Abdeckungen aus Edelstahl für

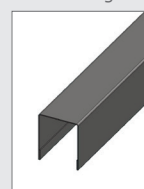

D05E P40

C D05E P40/13  
C D05E P40/18  
(1X)



D05E P90

C D05E P90  
(1X)

Profilo deviatore antischiacciamento - Perfil desviador anti aplastamiento - Seal against finger crush - Fingerklemmschutzprofil

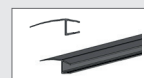

8PT1-33  
(1X)

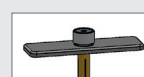

D05E P52  
(1X)

## D05E 70N SLASH system

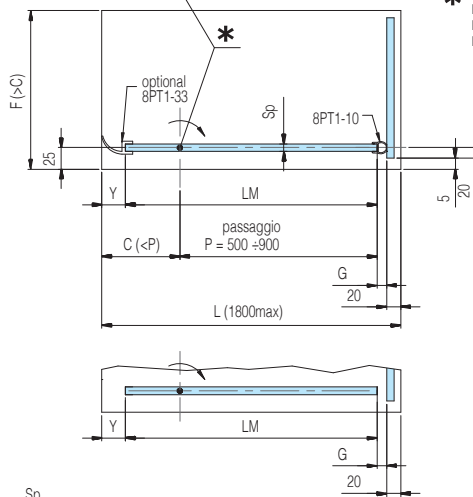
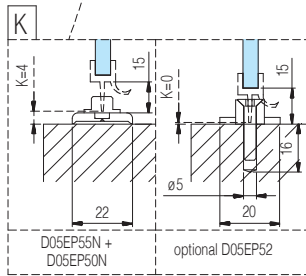
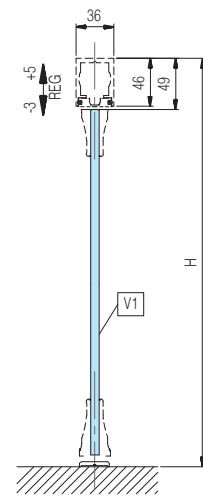
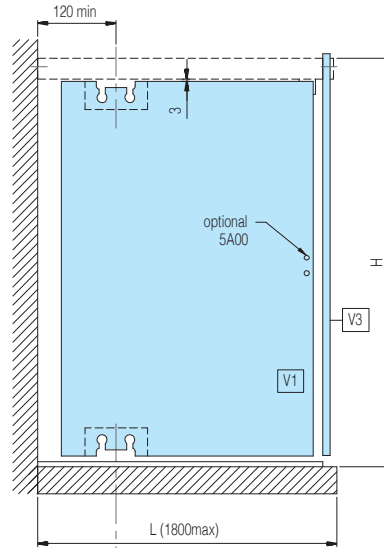
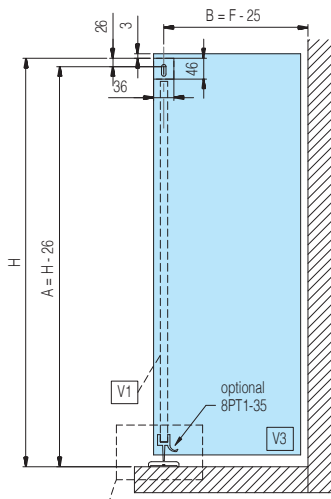

\* CENTRO DI ROTAZIONE  
PUNTO DE ROTACION  
ROTATION POINT  
LAGE DER DREHACHSE

Sp	Y	G
8mm	18mm	6mm
10mm	18mm	8mm

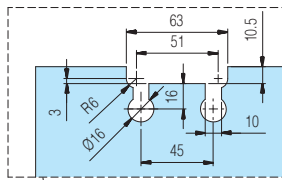

Sp	Y	G
8mm	3mm	3mm
10mm	3mm	3mm

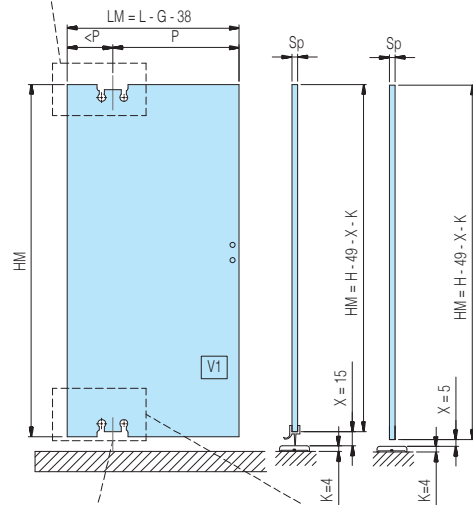

\* Definire il passaggio P voluto. Valutare il centro di rotazione e definire la larghezza LM totale.

Definir el pasaje P deseado. El centro de la vuelta de evaluar y definir el ancho total LM.

Define the desired passage P. Consider the rotation point and define the total width LM.

Den gewünschte Durchgang P definieren. Auf den Drehpunkt achten und die Gesamtbreite LM definieren.

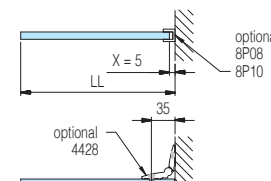
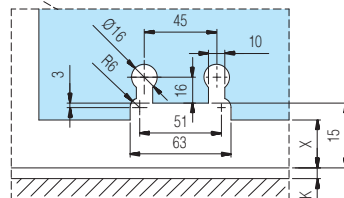
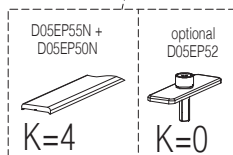
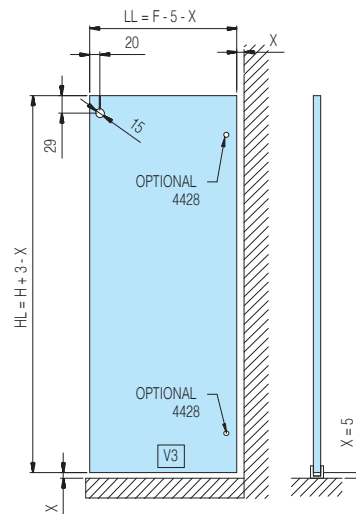

## D05E 72N

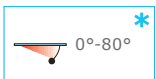

### SLASH oildynamic pivot system

- Kit Slash per box doccia con 1 spalla in vetro. Con vetro fisso frontale. Stop a +90°.
- Kit Slash para box ducha: 1 lado en vidrio. Frente de cristal fijo. Stop a +90°.
- Set Slash for shower tray wall-glass. One door and one fixed glass. Stop at +90°.
- Set Slash für Wand-Glas Dusche. Eine Tür und ein Seitenteil. +90° Feststellung.

\*  
È necessaria una battuta in chiusura in quanto la cerniera ha una precarica - Necesita de un cierre con tope, puesto que la bisagra tiene una precarga - The hinge is preloaded which makes an end stop necessary - Ein Anschlag ist notwendig, da der Beschlag eine Vorspannung besitzt.

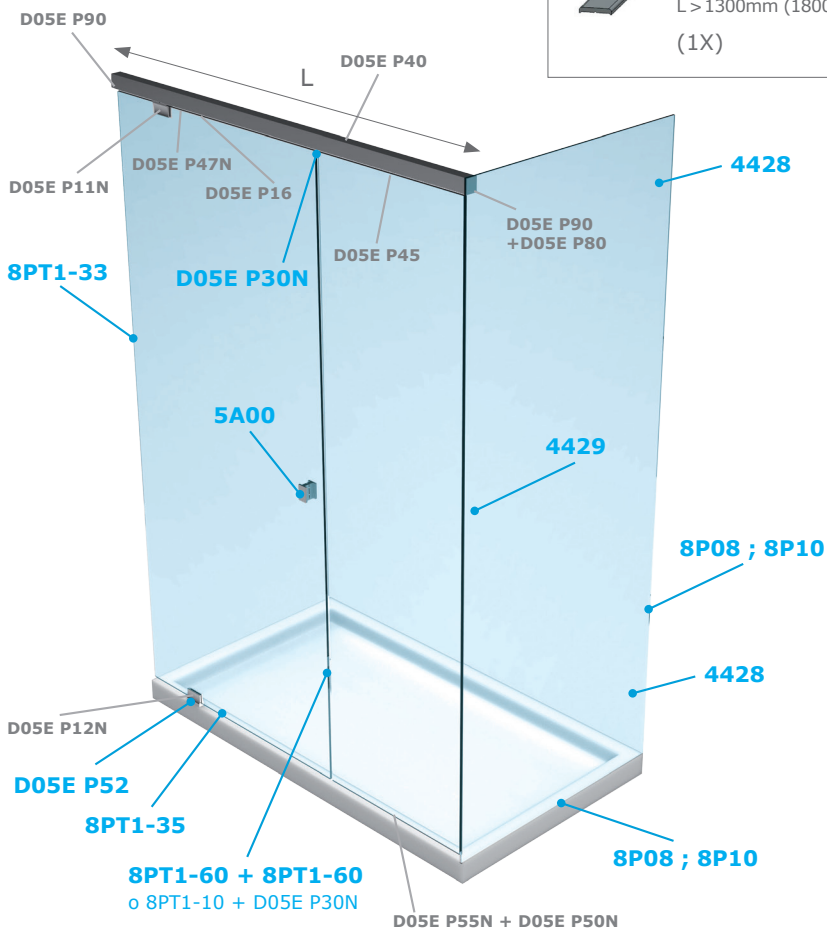

Da specificare all'ordine - Especificar en el pedido - Specify at time of order - Bitte mit der Bestellung genau angeben



D05E 72N/08



D05E 72N/10

### Compresso / Included



D05E P16 (1X)

D05E P11N/08 (1X)

(vetro/vidrio/glass/Glas 8mm)

D05E P11N/10 (1X)

(vetro/vidrio/glass/Glas 10mm)



D05E P47N (1X)



D05E P12N/08 (1X)  
(vetro/vidrio/glass/Glas 8mm)

D05E P12N/10 (1X)  
(vetro/vidrio/glass/Glas 10mm)



D05E P80 (1X)

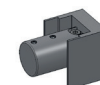

D05E P90 (2X)

### Non compreso / Not included

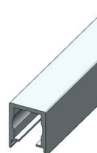

D05E P40/13 (1,25 mt)  
L ≤ 1300mm (630mm MIN)

D05E P40/18 (1,75 mt)  
L > 1300mm (1800mm MAX)  
(1X)

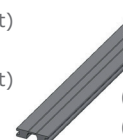

D05E P45/09 (0,9 mt)

(1X) L ≤ 900mm  
(2X) L > 900mm

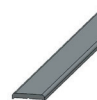

D05E P55N/13 (1,3 mt)  
L ≤ 1300mm (630mm MIN)

D05E P55N/18 (1,8 mt)  
L > 1300mm (1800mm MAX)  
(1X)



D05E P50N (1X)

### OPTIONAL

Coperture inox per - Cubiertas de acero inoxidable para - Stainless steel covers for - Abdeckungen aus Edelstahl für

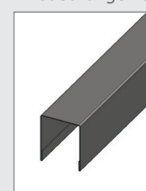

D05E P40

C D05E P40/13  
C D05E P40/18  
(1X)

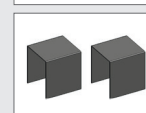

D05E P90

C D05E P90  
(1X)

Profilo deviatore antischiacciamento - Perfil desviador anti aplastamiento - Seal against finger crush - Fingerklemmschutzprofil



8PT1-33 (1X)

Fermo - Tope - Stop - Endanschlag

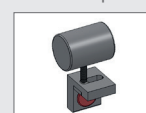

D05E P30N (1X)

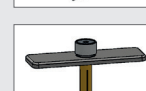

D05E P52 (1X)

**D05E 72N SLASH system**

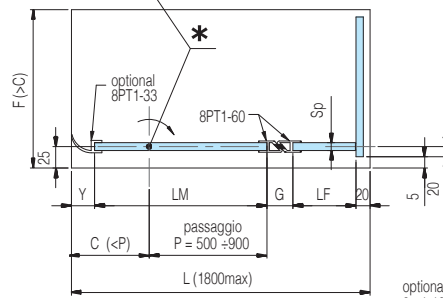
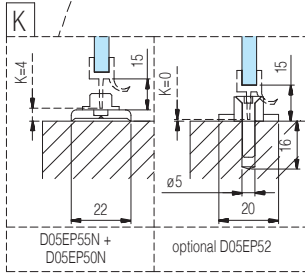
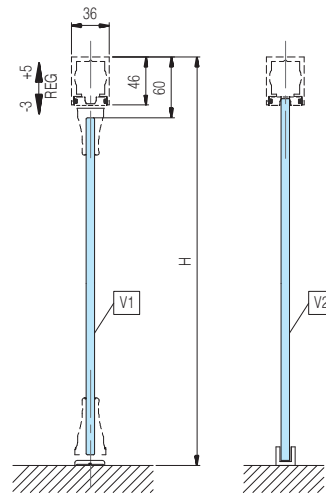
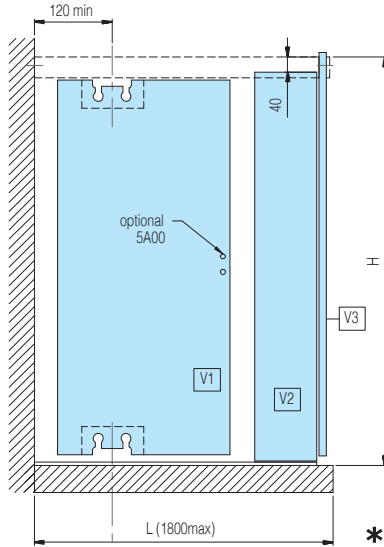
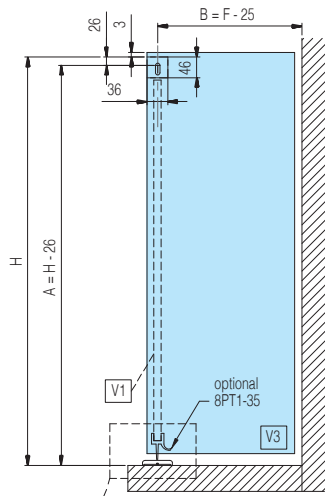

\* CENTRO DI ROTAZIONE  
PUNTO DE ROTACION  
ROTATION POINT  
LAGE DER DREHACHSE

\* Definire il passaggio P voluto. Valutare il centro di rotazione e definire la larghezza LM totale.

Definir el pasaje P deseado. El centro de la vuelta de evaluar y definir el ancho total LM.

Define the desired passage P. Consider the rotation point and define the total width LM.

Den gewünschte Durchgang P definieren. Auf den Drehpunkt achten und die Gesamtbreite LM definieren.

Sp	Y	G
8mm	18mm	22mm
10mm	18mm	26mm

Sp	Y	G
8mm	18mm	6mm
10mm	18mm	8mm

Sp	Y	G
8mm	3mm	3mm
10mm	3mm	3mm

