

31.80290.21

VERTO XL, VT 150E30, set charnières hydrauliques supérieures et inférieures pour portes lourdes

| | |
|-------------------------|------------------------|
| Matériau: | aluminium |
| Finition: | poli |
| Montage: | montage au plafond/sol |
| Épaisseur du verre: | 8 - 19 mm |
| Unité de vente (UV): | St |
| unité d'emballage (UE): | 1.00 |
| Forme: | carré |
| Travail du verre: | Encoche |
| Capacité de charge: | 150 kg/paire |

charnière inférieure avec fonction hydraulique, charnière supérieure avec fonction de freinage, réglage de la vitesse de fermeture, réglages des freinages contre les contraintes du vent, largeur max. de la porte 1200 mm, couvercles en inox, convient aux portes extérieures et intérieures, arrêt à 0° / +90° / -90°, fermeture automatique à partir de +80° et -80°, pour des températures de -10°C à + 50°C

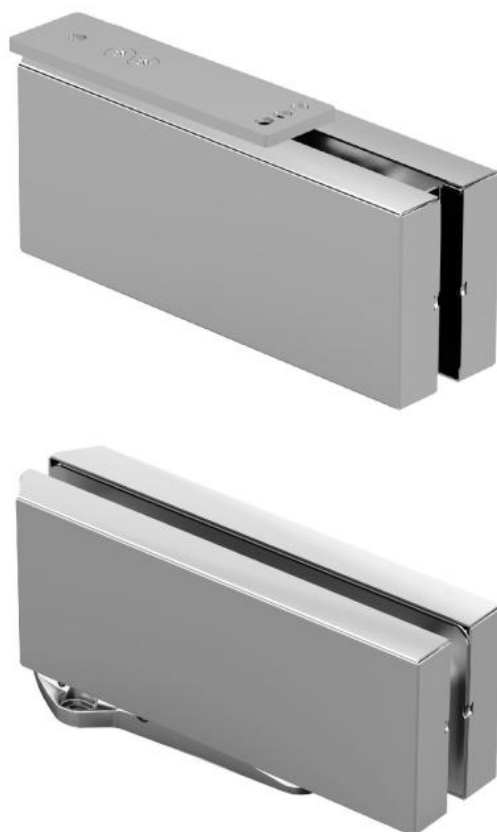

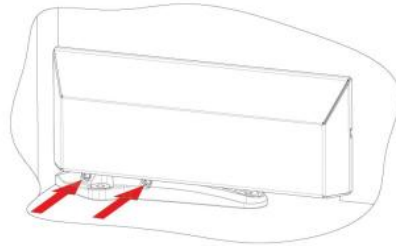
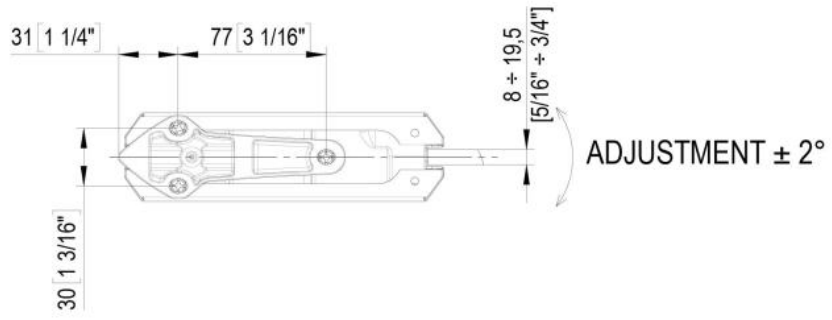

Door adjustment at 0°



ALIGNMENT
ADJUSTMENT ± 2°

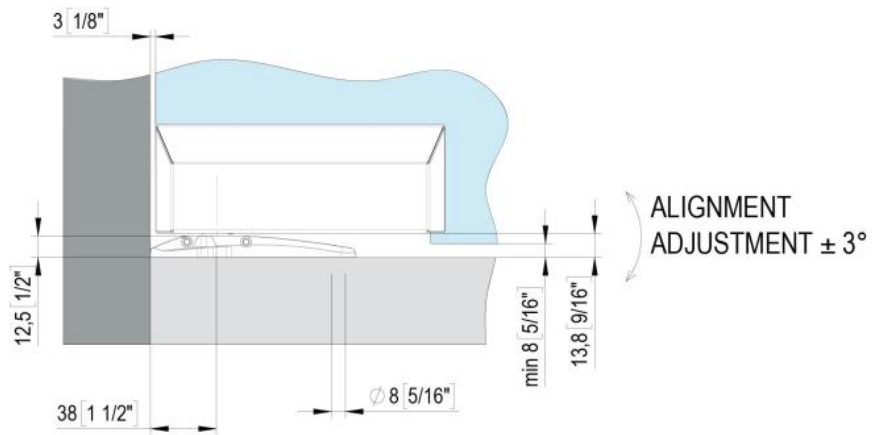

ALIGNMENT
ADJUSTMENT $\pm 3^\circ$

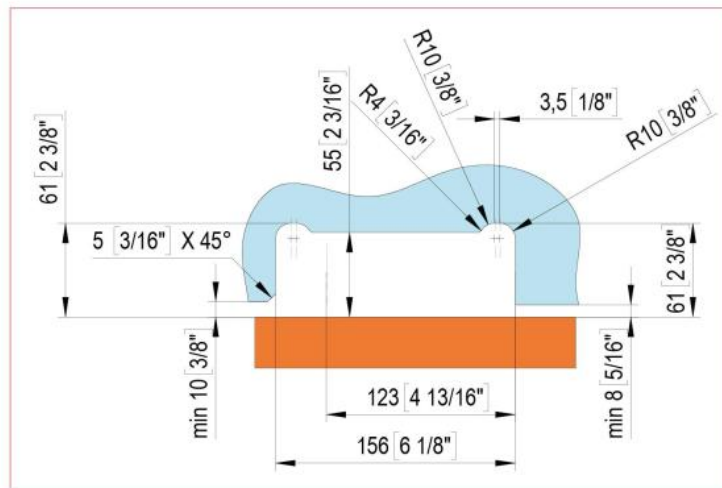
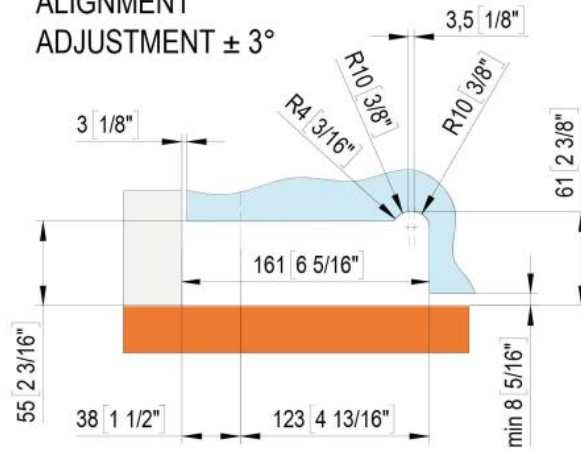

Lavorazione vetro per applicazione pivottante - Glass processing for pivoting applications

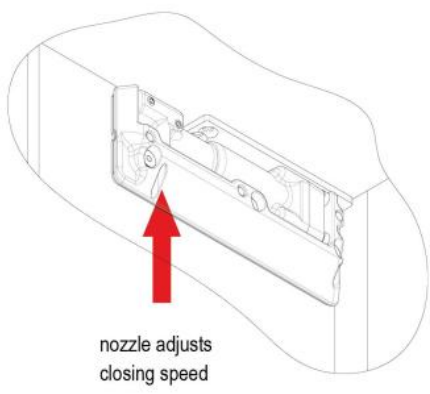
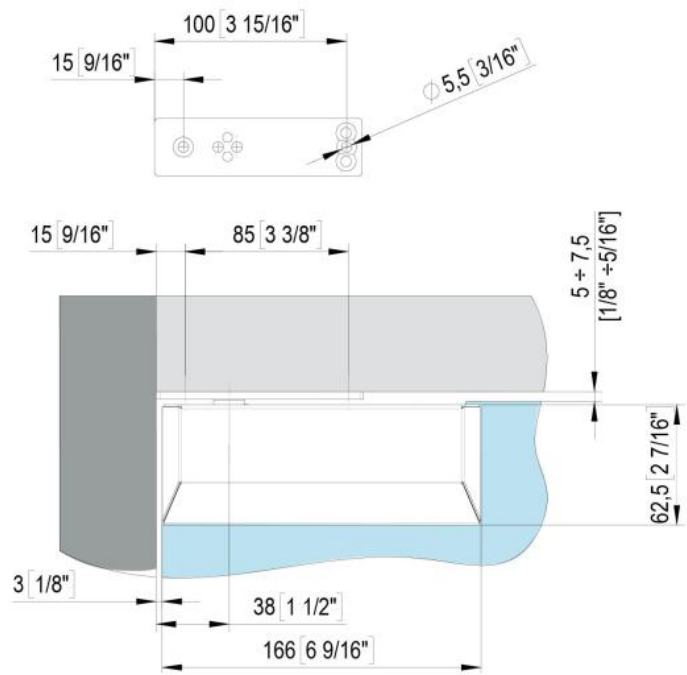

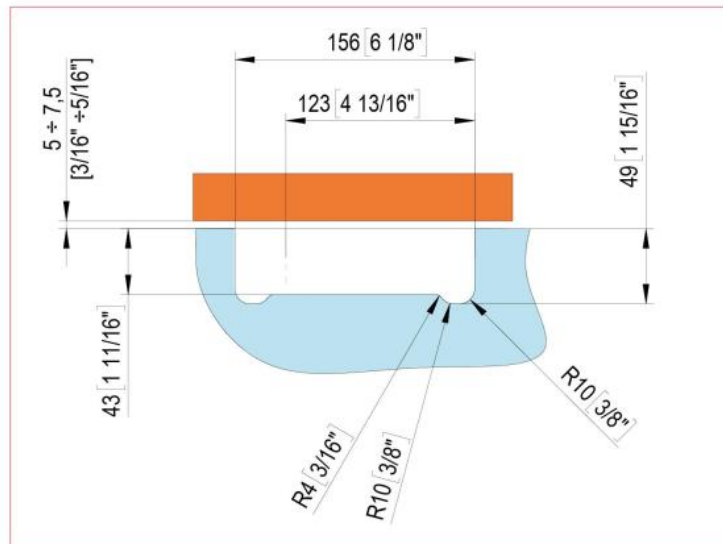
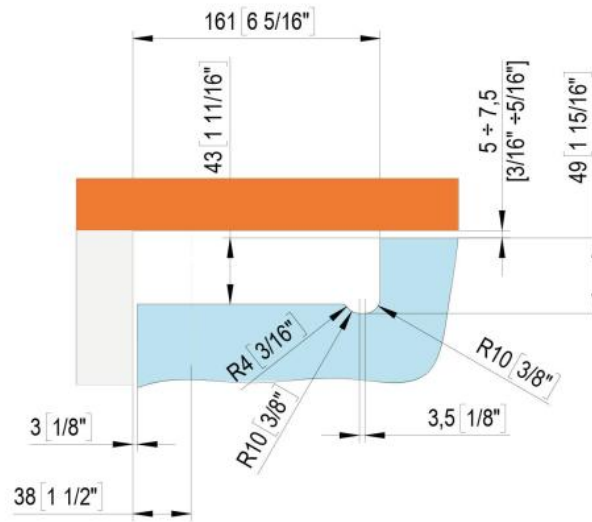

Lavorazione vetro per applicazione pivottante - Glass processing for pivoting applications

