

77.00120.16

Punkthalter fix mit Zylinderkopfschraube

Material: inox V2A
Finish: brushed
Glass thickness: 10 mm
Sales unit (SU): St
Unit package: 1.00
Measures: Ø 65 mm
Glass processing: Glass drill hole : Ø24 mm
Thread: M16

Gewindelänge 80 mm. Statik geprüft, max. Q = 2.0 kN, max. N = 8.1 kN



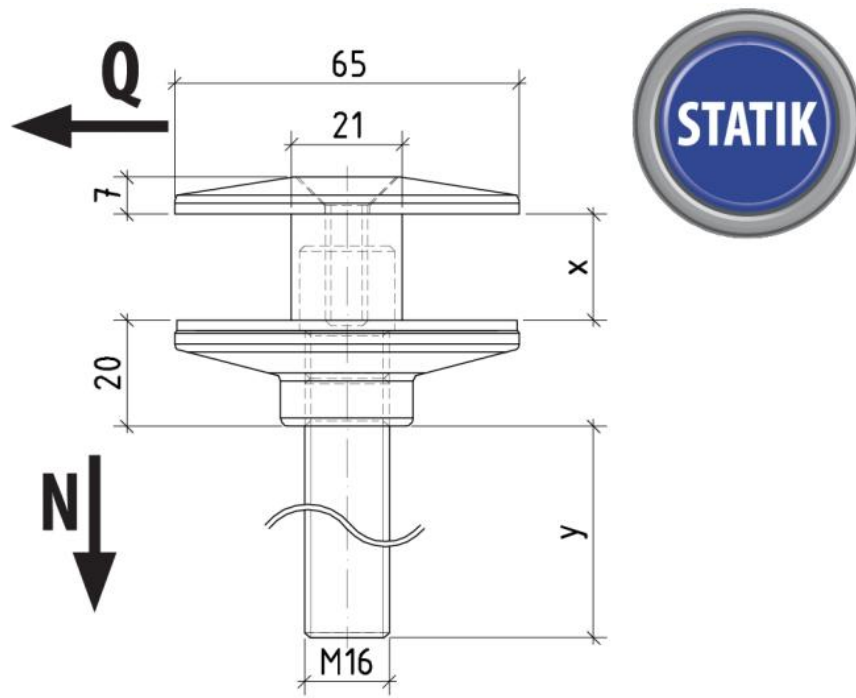

Statikgeprüft:
Max $Q = 2.0 \text{ kN}$
Max $N = 8.1 \text{ kN}$