

31.80290.21

VERTO XL, VT 150E30, set hinges hydraulic, upper and lower, for heavy doors

Material: aluminium
Finish: polished
Mounting: ceiling/floor assembly
Glass thickness: 8 - 19 mm
Sales unit (SU): St
Unit package: 1.00
Shape: square
Glass processing: Notch
Carrying capacity: 150 kg/pair

lower hinge with hydraulic function, upper hinge with brake function, closing speed adjustment, integrated brake against wind influences, final latch adjustment, max door width 1200 mm, covers made of ionx, suitable for exterior and interior doors, stop at 0° / +90° / -90°, automatic closing from +80° and -80°, for temperatures from -10°C to + 50°C



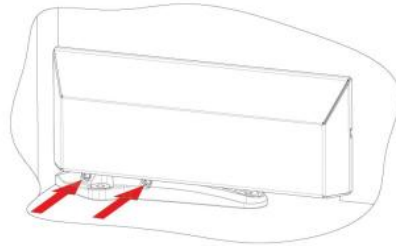
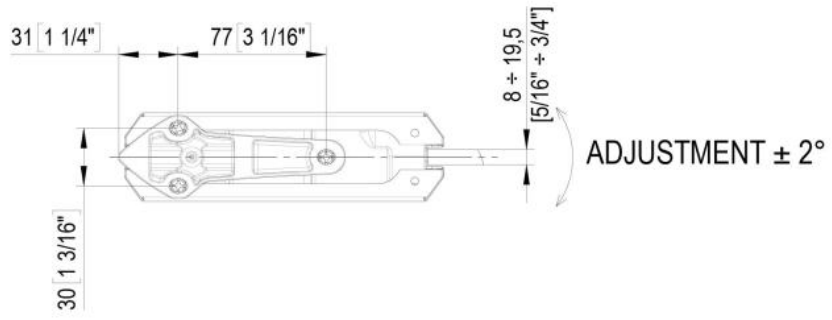

Door adjustment at 0°



ALIGNMENT
ADJUSTMENT ± 2°

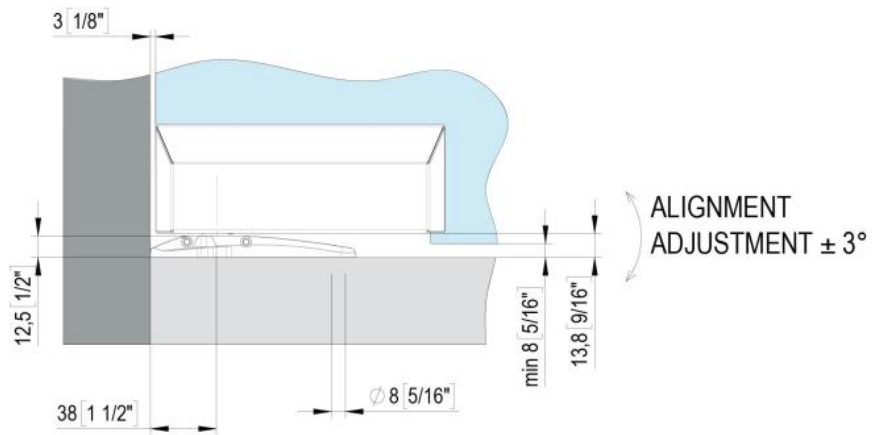

ALIGNMENT
ADJUSTMENT $\pm 3^\circ$

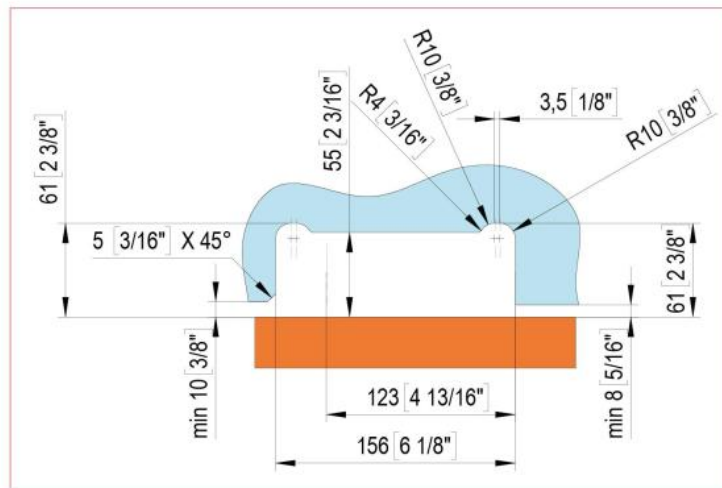
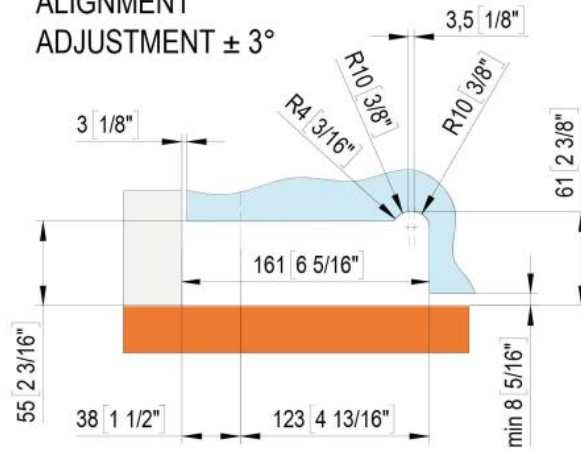

Lavorazione vetro per applicazione pivottante - Glass processing for pivoting applications

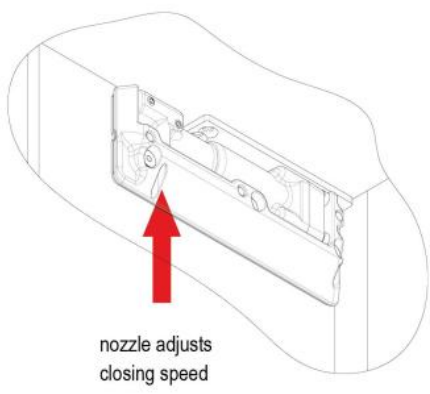
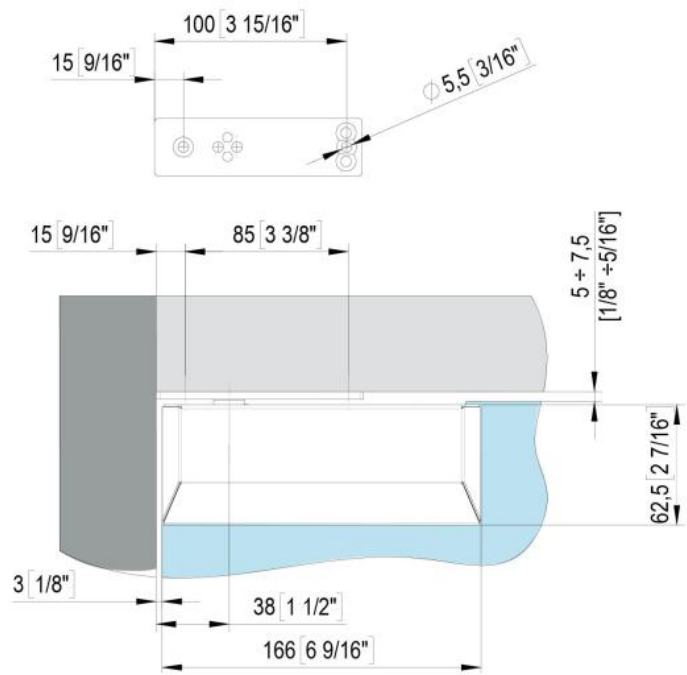

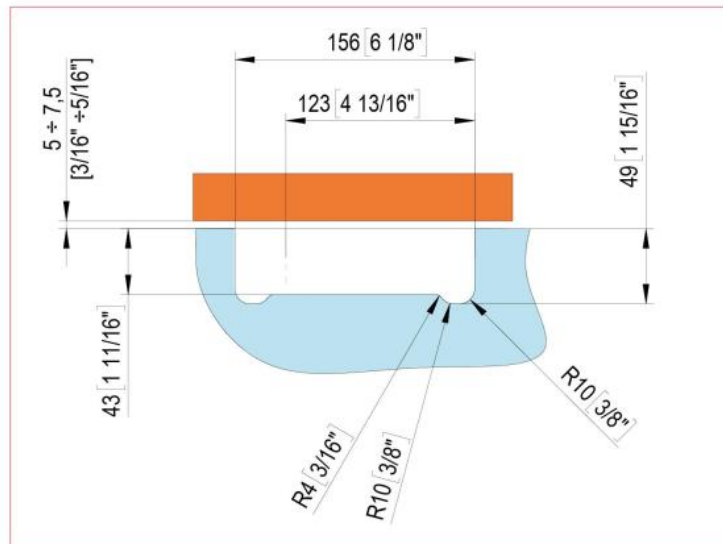
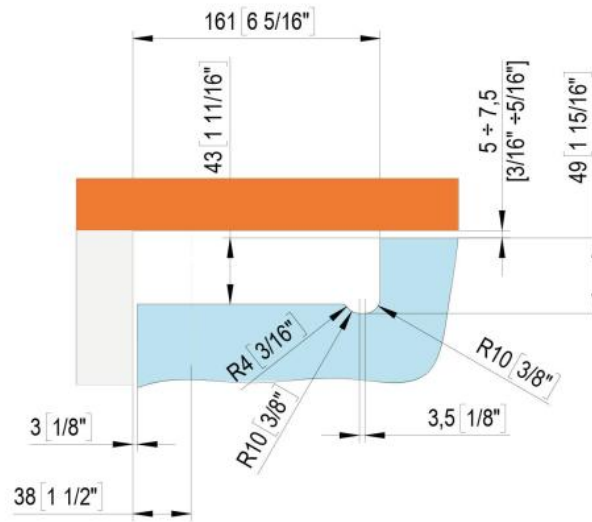

Lavorazione vetro per applicazione pivottante - Glass processing for pivoting applications

